



www.sampling.co.uk

FreeGlide®

2012



The only in-line Powder Sampler
guaranteed not to jam

FreeGlide®

...the smarter way to sample....

The FreeGlide is an inline powder sampler that is designed to take samples as powders fall under gravity down a pipe.



Manually Operated

Rear: FG-3000M
Front: FG-1500M



Pneumatic Actuation

FG-3000A

...the new generation in
In-line Powder Sampling

The FreeGlide® Benefits

The sample is collected in a cup. It is not subjected to any physical or thermal forces.

FreeGlide® Benefits

- The bore of the pipe is clear when the sampler is not in use
- The sample is collected in a 50ml cup
- All product contact parts are made from FDA acceptable materials
- Ideal for use in hygienic industries (pharmaceutical and food)

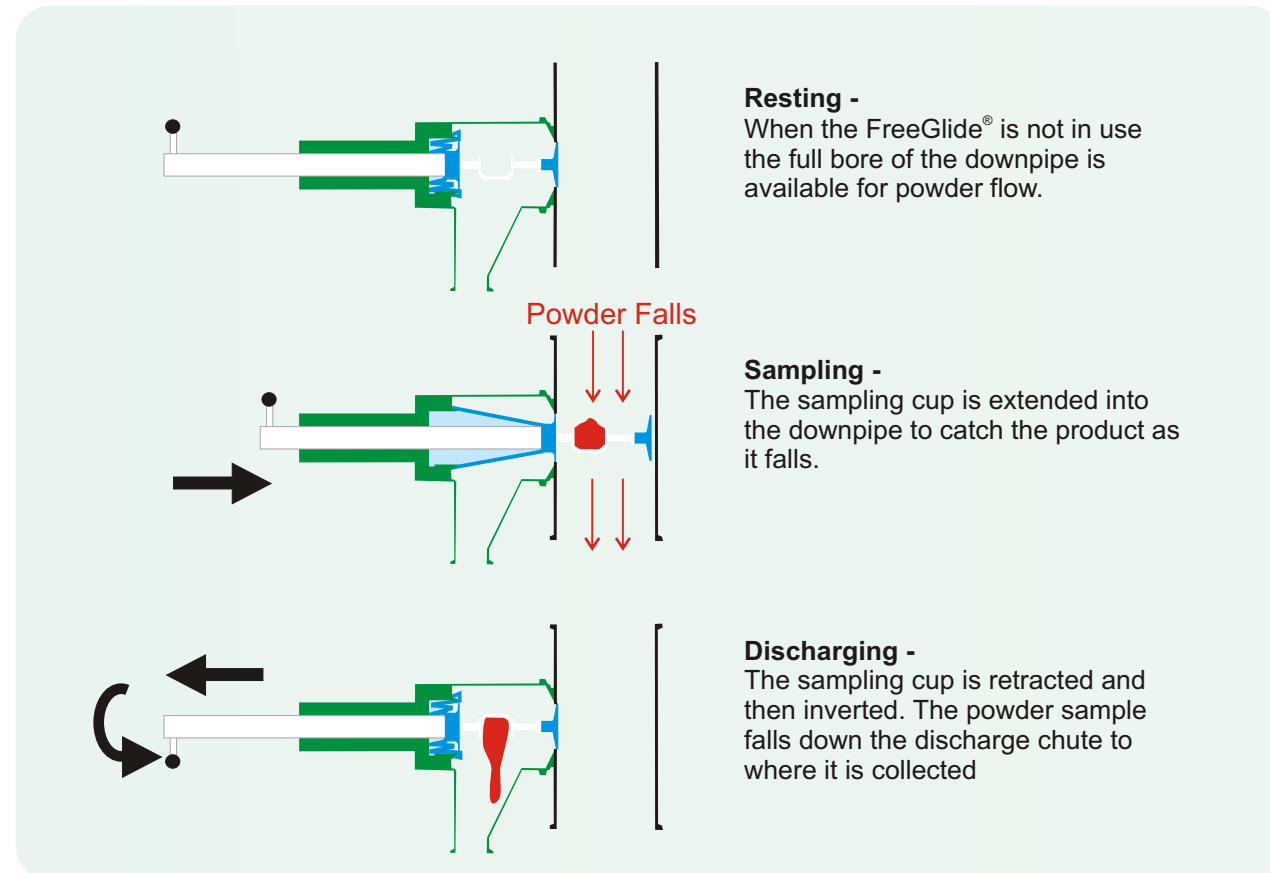

The FreeGlide[®] Diaphragm

The Diaphragm is the heart of the FreeGlide. It separates the product zone from the technical zone.



FreeGlide[®] Diaphragm

The Diaphragm is the unique flexible seal which is at the heart of the device. The diaphragm keeps the powder out of the technical area (where the bearings are). By keeping the bearings free from powders we can be sure that the sampler will not jam when in use.

Diaphragms are available in three FDA acceptable polymers: Silicone, Viton and EPDM.

Patent pending.

Manual or Automated?

The FreeGlide is available with manual or automated actuation



Automated FreeGlide®
Requires compressed air at 6 barg

Manual FreeGlide®

Manual Operation

The operator uses the handle at the rear of the sampler to extend, retract and rotate the sampling cup. There are no interlocks.

Automated Operation

Compressed air is used to extend, retract and rotate the sampling cup. Electrical sensors are used to detect the cup position.

FreeGlide[®] Sizes

The FreeGlide is available in a range of different sizes to suit different pipe diameters.

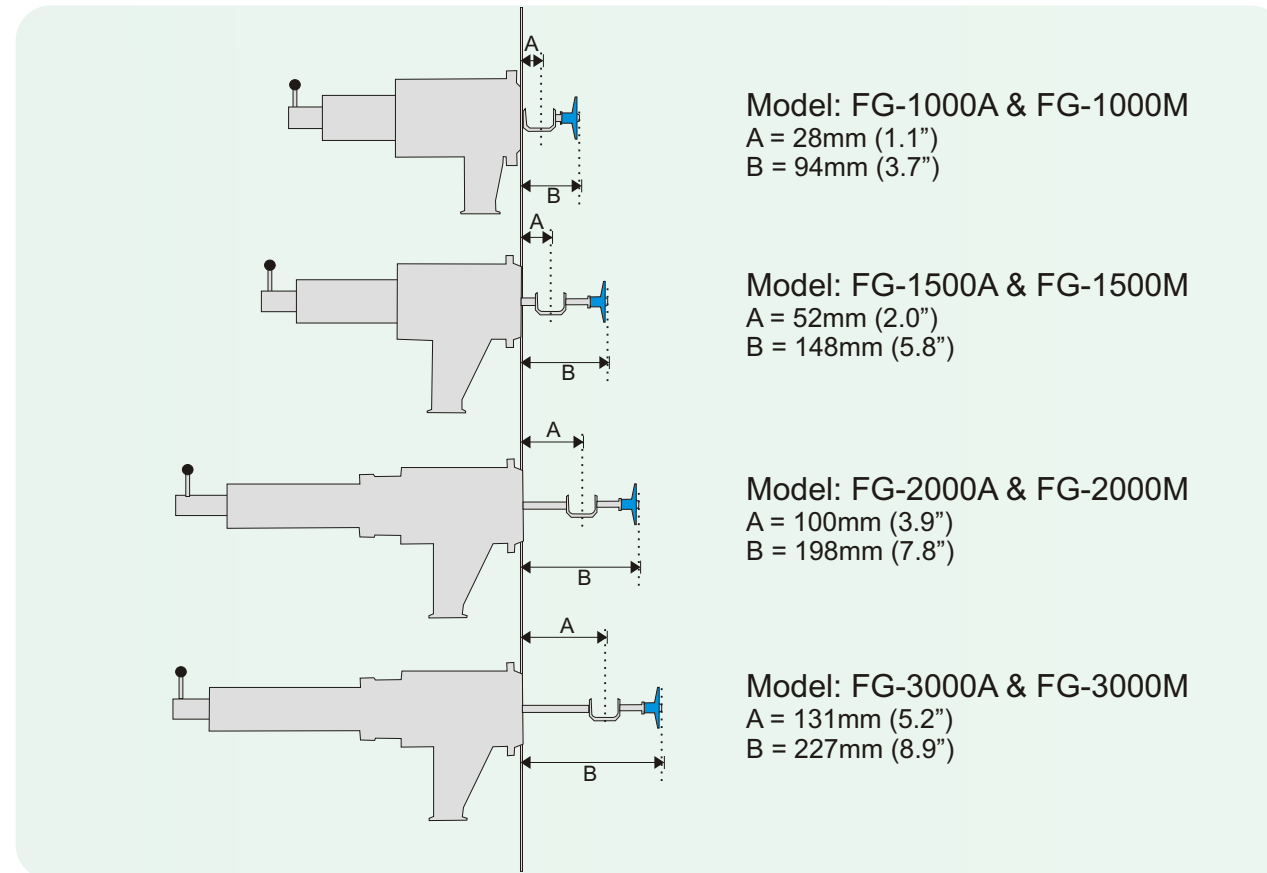

The FreeGlide[®] is available in four sizes. The size required will depend upon the diameter of the pipe where the FreeGlide[®] is to be installed.

Dimension A = distance to the centre line of the cup

Dimension B = distance to the end of the seal peg (this will be the minimum diameter of the pipe that the FreeGlide[®] can be installed in)

FreeGlide[®] Installation

The FreeGlide can be quickly removed when it is not required.



1. Cut a hole in your downpipe
2. Weld the Front Boss to your downpipe.
3. The main body of the FreeGlide[®] then clamps to the front flange

Note: The FreeGlide[®] can be easily removed for cleaning. A Blanking Plate can be used to cover the front boss when the FreeGlide[®] is not in use

FreeGlide[®] Technical

The FreeGlide is ideal for sampling powders as they fall under gravity down a pipe.



Sample Cup Size: 50ml

Contact parts:

- 316 stainless steel
- PTFE
- Silicone rubber, Viton[®] or EPDM

Non contact parts:

- 304 grade stainless steel
- Other materials as required.

Finishes: All welds ground and polished to surrounding metal standard.
All product contact surfaces are finished to Ra 0.5µm (20 micro inch) or finer.

Actuation: Manual or Pneumatic actuated
Actuated FreeGlides[®] are supplied with reed and limit switches so they can be connected directly to your PLC. Please contact us for more info.

Dimensions: Please contact us for planning in drawings

Sizes & Part Numbers:

Minimum Downpipe Diameter	Manual Operation	Automated Operation
100mm (4")	FG-1000M	FG-1000A
150mm (6")	FG-1500M	FG-1500A
200mm (8")	FG-2000M	FG-2000A
230mm (9.5")	FG-3000M	FG-3000A

Location: The Free-Glide[®] is designed for the collection of powder samples from a vertical downpipe. The product needs to be dispersed in air and in free fall

Pipe Pressure: The internal pressure differential across the device (inside/outside of the downpipe) needs to be within 0.1 barg of surrounding atmospheric pressure. Ask for advice if greater pressure differentials are required.

Flexible Parts: Polymer components are available in the following FDA acceptable materials: Silicone, Viton or EPDM



ATEX: Ex II 2GD T4 (extra cost option)



© Sampling Systems Ltd. 2012.
All rights reserved.

FreeGlide[®] is a registered trademark belonging to Sampling Systems Ltd.

Viton[®] is a registered trademark belonging to DuPont Performance Elastomers L.L.C

Patent Pending

Sampling Systems Ltd.

4 & 5 Forge Mills Park, Station Road, Coleshill, Warwickshire. B46 1JH. UK.
Tel: +44 (0)1675 466992 Fax: +44 (0)1675 466994 Email: info@sampling.co.uk Web: www.sampling.co.uk

